



1325 South Cicero Avenue
Cicero, Illinois 60804-1804

800.545.6200
708.652.5600
708.780.6975 fax
www.lbpmfg.com



Combining innovation, performance and the environment

This catalog is printed on:



www.lbpmfg.com



Revolutionizing Foodservice Packaging

LBP develops products with every customer in mind, from the distributors who carry and represent our line to the end users who ultimately interact with our packaging.

Fresh Design & Innovative Solutions- highlighted by LBP's patented Beverage on the Move™. This bulk beverage carrier features a self-inflating inner bag for quick and easy filling. Consumers can now take 8 cups of coffee in a single, disposable, simple to carry package. It is this thoughtful union of attractive form and multi-level function that makes LBP's packaging solutions the perfect fit.

Commitment to the Environment

LBP is committed to making decisions based on key performance criteria while responsibly using the best available environmentally friendly components. Our products represent the highest post-consumer fiber content raw materials with a sincere focus on recyclability.

We are members and supporters of organizations such as:

- Conservation International - helping their mission to conserve Earth's natural heritage.
- World Wildlife Federation- Helping their mission to protect endangered species and their habitats.
- Sustainable Packaging Coalition- helping their mission to advocate and communicate a positive robust environmental vision for packaging.

Our commitment extends beyond the raw materials sourced to include packaging designed with minimal waste through production, maximum layout utilization, reduction of secondary packaging, and cube optimization while in transit and storage.

LBP actively reviews, researches, sources, and tests new materials to create packaging that continually reduces our environmental footprint.



Looking for environmental information on a certain product? Look for this leaf symbol.



Product is made with recycled material

Please note with our ever developing industry, this catalog is continually changing. As we strive to ensure this and all of our printed information is accurate, we would like to advise you to check with your local customer service representative for the most up-to-date information.



Inside

1 clamshells



3 hot cup sleeves



7 bulk beverage



9 handled carriers



11 catering



13 lunch boxes & drink carriers



15 cups



17 lids

19 innovation & customization

www.lbpmfg.com

800.545.6200

clamshells

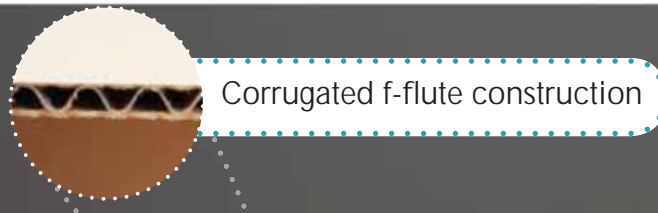

Corrugated f-flute construction



Contains high percentage of recycled material.

Grease resistant barrier means no need for paper or a wax sheet.



Locking Feature
Side locking feature allows for a quick secure lock every time.

Thermal Insulation
Construction allows premium heat retention and structure stability.

Unique Features

- **Micro-flute** insulation maintains food temperature and preserves appearance by eliminating condensation.
- Approved for direct food contact.
- Locking feature allows for a secure close every time.
- White exterior/kraft interior.
- Custom printing available

Clamshells

- Hot Cup Sleeves
- 96 oz. To Go
- Bulk Beverages
- Handled Carriers
- Catering
- Boxes & Carriers
- Cups
- Lids
- Innovation



Product Description	Burger White/Kraft	Deluxe Sandwich White/Kraft	Personal Pizza White/Kraft	Sub Sandwich White/Kraft
Item Number	5000	5100	5200	5300
Case Pack	400	200	250	400
Product Dimensions	4 x 4 x 3	5 ¹ / ₂ x 5 ¹ / ₂ x 3	6 ¹ / ₂ x 6 ¹ / ₂ x 2 ¹ / ₈	7 ³ / ₄ x 3 ¹ / ₄ x 3
Case Dimensions	23 ³ / ₈ x 19 ⁷ / ₈ x 16 ³ / ₄	29 x 13 ³ / ₈ x 15 ¹ / ₄	24 ⁷ / ₈ x 14 ⁷ / ₈ x 17 ³ / ₄	28 ³ / ₈ x 20 ¹ / ₈ x 16 ⁵ / ₈
Case Cube	4.50	3.42	3.80	5.49
Case Weight (lbs)	23	19	22	30
Cases Per Pallet	20	16	20	12



Product Description	Lunch White/Kraft	Deluxe Personal Pizza White/Kraft	Dinner White/Kraft	Breadsticks White/Kraft	Rib Dinner (half slab) White/Kraft
Item Number	5400	5500	5600	5700	5800
Case Pack	200	200	125	200	126
Product Dimensions	8 x 6 x 3	8 x 8 x 2 ¹ / ₈	9 x 9 x 3	11 x 3 ¹ / ₂ x 2	11 x 5 x 2 ¹ / ₂
Case Dimensions	28 ³ / ₈ x 14 ³ / ₈ x 20 ³ / ₈	19 ¹ / ₈ x 18 ¹ / ₄ x 21 ¹ / ₄	20 ³ / ₈ x 17 ³ / ₈ x 22 ³ / ₄	24 ¹ / ₈ x 13 ⁵ / ₈ x 18 ¹ / ₈	15 ¹ / ₂ x 14 x 24 ⁷ / ₈
Case Cube	4.81	4.29	4.66	3.45	3.12
Case Weight (lbs)	23	19	21	22	17
Cases Per Pallet	16	16	24	24	27



hot cup sleeves



Hot cup sleeves contain both recycled and post-consumer fiber content.

Our newest addition, the Eco Clutch™ contains a 100% post-consumer fiber content.

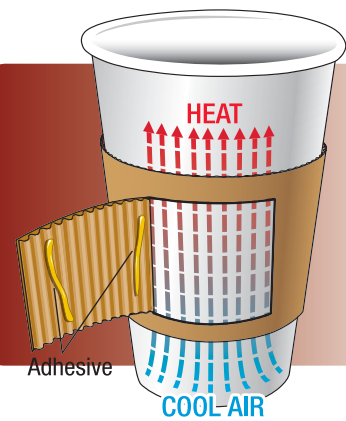

Heat-Activated Adhesive

Our patented hot cup sleeves stick to the cup with heat - activated adhesive.

Corrugated Design releases heat around hand while cool air is drawn in.

Clamshells

96 oz. To Go

Bulk Beverages

Handled Carriers

Catering

Boxes & Carriers

Cups

Lids

Innovation

Hot Cup Sleeves

Unique Features

- **Coffee Clutch®** - **Corrugated** construction provides superior insulation.
- **Wave Sleeve™** - **Fluted** design is easy to grip.
- **The Sleeve™** - Alternative design made from **Embossed Paperboard** creates a unique texture.
- Custom printing available



Product Description	Eco Clutch™ 10, 12, 16, 20 oz. - Kraft	Coffee Clutch® 10, 12, 16, 20 oz. - White	Coffee Clutch® 10, 12, 16, 20 oz. - Kraft	Coffee Clutch® 8 oz. - Kraft
Item Number	6772	6107	6106	6430
Case Pack	1200	1200	1200	1200
Case Dimensions	19 ¹¹ / ₁₆ x 15 ¹ / ₄ x 8 ⁷ / ₈	19 ¹¹ / ₁₆ x 15 ¹ / ₄ x 8 ⁷ / ₈	19 ¹¹ / ₁₆ x 15 ¹ / ₄ x 8 ⁷ / ₈	19 ¹¹ / ₁₆ x 14 ¹ / ₄ x 8 ¹ / ₂
Case Cube	1.54	1.54	1.54	1.38
Case Weight (lbs)	19	19	19	15
Cases Per Pallet	54	54	54	54



Product Description	Wave Sleeve™ 10, 12, 16, 20 oz. - Kraft	The Sleeve™ 10, 12, 16, 20 oz. - Kraft	Sleeve Dispenser Clear Acrylic with header card
Item Number	6482	6000	61030
Case Pack	1200	1200	1
Case Dimensions	20 ⁵ / ₁₆ x 15 ¹ / ₄ x 9 ¹ / ₈	15 ¹ / ₄ x 15 ¹ / ₄ x 8 ³ / ₄	9 ⁵ / ₈ x 9 ¹ / ₈ x 18 ¹ / ₈
Case Cube	1.64	1.18	.93
Case Weight (lbs)	19	22	5
Cases Per Pallet	54	42	105

The Sleeve™ - U.S. Patent #5,826,786
Coffee Clutch®, Wave Sleeve™ and Eco Clutch™ - US #5205473 and #6863644; GB #2382049; HK #1055927; SG #102961; CH #ZL01823711.8; RU #2264294; ID #W00200400534; and other patents pending.



96 oz. to go



The corrugated structure contains both recycled and post-consumer fiber content.

Inner bag contains recyclable materials and can be recycled under plastic ID code Number 7.

Printed with soy or water-based inks.

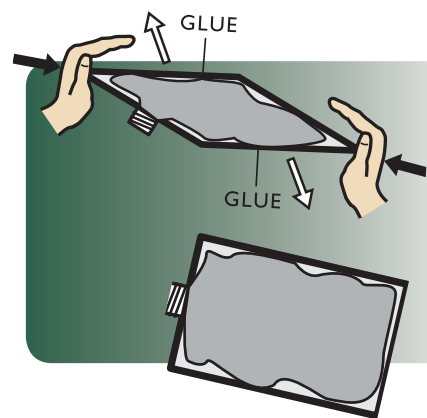

Pop, Fill, & Go™
Inner bag automatically inflates for quick and continuous filling.
Sanitary - no need to handle bag.

Unique Features

- Insulates 96 oz. (eight 12 oz. servings) of hot or cold beverages for up to 3 hours.
- Compatible with brewer or carafe systems.
- One-piece product stores flat for storage efficiency and assembles in seconds.
- **The Caddy™** - Attaches easily to the Beverage on the Move™ handle and provides portion control for cups, napkins, sugar, cream, or other necessities.
- Custom printing available

96 oz. To Go

- Clamshells
- Hot Cup Sleeves
- Bulk Beverages
- Handled Carriers
- Catering
- Boxes & Carriers
- Cups
- Lids
- Innovation



Product Description	Beverage on the Move™ 96 oz. Running Cup Print	Beverage on the Move™ 96 oz. Border Print	Beverage on the Move™ 96 oz. 100% Coffee Print
Item Number	7175	7174	7311
Case Pack	25	25	25
Case Dimensions	19 ¹ / ₈ x 15 ⁵ / ₈ x 16 ¹ / ₂	19 ¹ / ₈ x 15 ⁵ / ₈ x 16 ¹ / ₂	19 ¹ / ₈ x 15 ⁵ / ₈ x 16 ¹ / ₂
Case Cube	2.85	2.85	2.85
Case Weight (lbs)	15	15	15
Cases Per Pallet	30	30	30



Product Description	Beverage on the Move™ 96 oz. Coffee Bean Print	Beverage on the Move™ 96 oz. Passport Print	The Caddy™ Condiment Carrier
Item Number	7312	7308	7139
Case Pack	25	25	100
Case Dimensions	19 ¹ / ₈ x 15 ⁵ / ₈ x 16 ¹ / ₂	19 ¹ / ₈ x 15 ⁵ / ₈ x 16 ¹ / ₂	15 ³ / ₈ x 9 ³ / ₈ x 11
Case Cube	2.85	2.85	.92
Case Weight (lbs)	15	15	13
Cases Per Pallet	30	30	60

Beverage on the Move™ (96 oz. + 160 oz.) - U.S. Patent #5,715,992, #5,909,841, #6,196,452, #6,290,124, #7,707,309 B2, #2436006, and Foreign Patent #86237 (CH), #HK1016944 and other U.S. and foreign patents pending.



bulk beverage



Catering and 160 oz Beverage on the Move™ are both made with recycled material and are recyclable.

Wide Mouth Beverage on the Move™ is made with recycled and post-consumer content.

Wide Mouth Beverage on the Move™

- One-piece product stores flat and assembles in seconds.
- Patented Pop, Fill & Go™ feature automatically inflates inner bag during assembly for fast filling.
- Wide Mouth opening allows for an easy fill and quick serve.

Catering Beverage on the Move™

- Holds Fifty-four 8 oz. servings.
- Two-spout design for easy filling and dispensing (no drip dispensing spout keeps serving site clean).
- Angled platform in base creates natural flow of liquid to spout, enabling a continuous uninterrupted stream.

Beverage Carafe™

- Durable pre-assembled construction eliminates operation set-up time.
- Wide mouth opening is easy and safe to fill and serve by operator or end user.

Clamshells

Hot Cup Sleeves

96 oz. To Go

Handled Carriers

Catering

Boxes & Carriers

Cups

Lids

Innovation

Unique Features

- Excellent for "drop and go" catering.
- Eliminates the need to clean, replace or take deposits on non-disposable equipment.
- Perfect for hot or cold beverages, soups, sauces, etc.
- Holds heat of hot beverages for up to 3 hours.
- Custom printing available

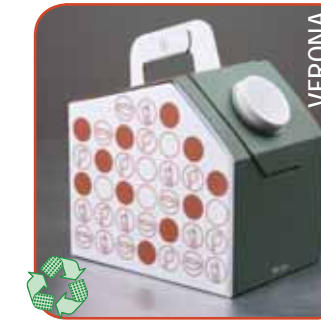
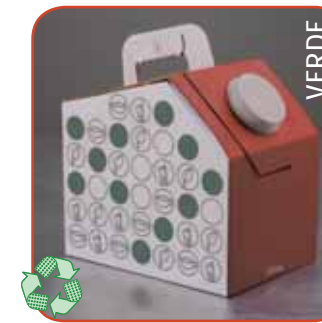

Product Description	Beverage on the Move™ Wide Mouth 96 oz. Verde Print	Beverage on the Move™ Wide Mouth 128 oz. Verona Print	The Caddy™ Condiment Carrier - Wide Mouth - Kraft
Item Number	9921	9922	9924
Case Pack	25	25	100
Case Dimensions	19 ¹ / ₈ x 15 ⁵ / ₈ x 16 ¹ / ₂	19 ¹ / ₈ x 15 ⁵ / ₈ x 16 ¹ / ₂	13 ⁵ / ₈ x 8 ¹ / ₈ x 10 ⁷ / ₈
Case Cube	2.85	2.85	.70
Case Weight (lbs)	16	16	11
Cases Per Pallet	30	30	72

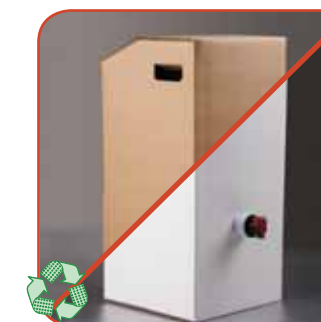

Product Description	Beverage on the Move™ 160 oz. Border Print *	Beverage on the Move™ 3 Gallon Catering - Kraft	Beverage on the Move™ 3 Gallon Catering - White	Beverage Carafe™ Wide 128 oz. - Azzuro Print
Item Number	6999	7150	7152	9919
Case Pack	20	10	10	8 assembled
Case Dimensions	19 ³ / ₄ x 18 ⁵ / ₈ x 12 ³ / ₈	35 ³ / ₈ x 15 ³ / ₈ x 19 ¹ / ₈	35 ³ / ₈ x 15 ³ / ₈ x 19 ¹ / ₈	23 ⁷ / ₈ x 19 ⁷ / ₈ x 14 ¹ / ₈
Case Cube	2.63	6.02	6.02	3.88
Case Weight (lbs)	15	18	18	15
Cases Per Pallet	24	12	12	20

Beverage on the Move™ (96 oz. + 160 oz.), 96oz Wide Mouth, 128oz Wide Mouth - U.S. Patent #5,715,992, #5,909,841, #6,196,452, #6,290,124, #7,707,309 B2, #2436006, and Foreign Patent #86237 (CH), #HK1016944 and other U.S. and foreign patents pending.
Catering Beverage on the Move™ (3 Gallon) - U.S. Patent #6,736,289B2 and other U.S. and foreign patents.
Beverage Carafe™ - U.S. Patent: 6375040 and other U.S. and foreign patents pending.
* 160 oz. does not include Pop, Fill, & Go™ feature.



handled carriers



Made with recycled and post-consumer content.

Sturdy construction enables product to be reused.

Folds flat for efficient storage or while in transit.



Safe Pak™ Locking Feature

Top lock easily snaps into place for a secure and snug fit every time.

Handled Carriers

- Clamshells
- Hot Cup Sleeves
- 96 oz. To Go
- Bulk Beverages
- Catering
- Boxes & Carriers
- Cups
- Lids
- Innovation

Unique Features

- **Safe Pak™** - Sturdy take-out alternative with easy to carry handle. White outside / kraft inside.
- **Bagel Box** - Tapered paperboard design that is great for bagels, pastries, muffins and more. Holds approximately one dozen bagels and 2 cream cheese tubs
- Custom printing available



Product Description	Bagel Box Kraft	Safe Pak™ White	Safe Pak™ White
Item Number	9600	9552	9548
Case Pack	100	50	50
Product Dimensions	8 1/2 x 8 1/2 x 8 3/8	12 1/4 x 10 1/4 x 11 1/2	8 1/2 x 5 1/2 x 3 1/2
Case Dimensions	18 x 16 1/4 x 12 1/2	23 1/4 x 10 1/4 x 26 1/4	15 x 9 x 13 5/8
Case Cube	2.12	3.62	1.06
Case Weight (lbs)	32	39	14
Cases Per Pallet	24	18	65



Product Description	Safe Pak™ Kraft	Safe Pak™ White	Safe Pak™ White	Safe Pak™ White
Item Number	9511	9549	9550	9551
Case Pack	50	50	50	50
Product Dimensions	9 1/4 x 6 1/4 x 6 3/4	9 1/4 x 9 1/4 x 6 3/4	12 1/4 x 12 1/4 x 4	12 1/4 x 12 1/4 x 4
Case Dimensions	16 1/4 x 10 1/8 x 17 3/4	19 1/4 x 10 1/8 x 20 3/8	24 7/8 x 10 1/8 x 21	24 7/8 x 10 1/8 x 21
Case Cube	1.69	2.30	3.06	3.06
Case Weight (lbs)	14	25	28	28
Cases Per Pallet	40	32	18	18



catering



Catering Tray Side Locks - Secure inside tray.

Strong Corrugated Construction

Catering Tray Stacking Locks - Secures multiple trays during transport for easy drop and go catering.



Made from recycled corrugated materials.

Economical and environmentally friendly.

Disposable alternatives to plastic and aluminum serving trays.

Printed with water and soy based inks.

Product case packed flat to save space and assembles in minutes.

Catering Square

- Durable corrugated 2-piece tray and lid with window offers great visibility for easy product identification.
- Windowed lid can flip open or completely be removed.

Catering Trays

- Designed to fit half and full aluminium steam table pans respectively.

Soup - N - Serve™

- Transport and serve soup, gravy, sauces, or fruit, potato, and pasta salads in a simple to use package.

Catering

- Clamshells
- Hot Cup Sleeves
- 96 oz. To Go
- Bulk Beverages
- Handled Carriers
- Boxes & Carriers
- Cups
- Lids
- Innovation

Unique Features

- **Catering Square** - Perfect for transporting heavy food products - sandwiches, baked goods, pastas, entrées and more.
- **Soup-N-Serve** - 2 piece set maintains food temperature during transport. Handles fold back and lock into place for unobstructed transport.
- **Catering Tray** - Inner tray folds down for service.
- Custom printing available

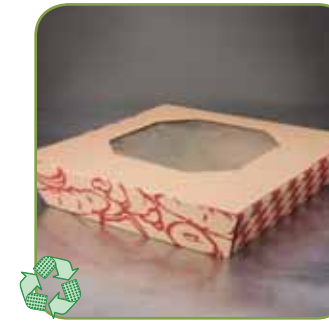
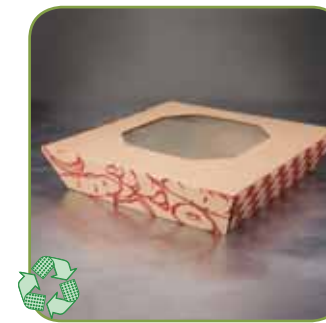

Product Description	16" Catering Square with windowed lid	18" Catering Square with windowed lid	Soup-N-Serve™ 128 oz. includes bucket and lid
Item Number	85201	85301	9690
Case Pack	35 sets	35 sets	15 sets
Case Dimensions	26 ⁵ / ₈ x 5 ¹ / ₂ x 26 ⁷ / ₈	28 ³ / ₄ x 5 ¹ / ₂ x 29	18 ³ / ₈ x 16 ³ / ₈ x 11 ¹ / ₄
Case Cube	2.28	2.65	1.96
Case Weight (lbs)	23	28	12
Cases Per Pallet	20	20	36



Product Description	Small Catering Tray (half steam pan) Overall: 15 ³ / ₈ x 10 ⁷ / ₈ x 4 ⁷ / ₈	Large Catering Tray Overall: 20 ¹ / ₄ x 13 ³ / ₄ x 4 ⁷ / ₈	Extra Large Catering Tray (full steam pan) Overall: 23 ¹ / ₂ x 13 ³ / ₈ x 4 ⁷ / ₈
Item Number	9631	9619	9632
Case Pack	15 sets	15 sets	15 sets
Product Dimensions	Tray: 13 x 10 ¹ / ₈ x 4 ³ / ₈	Tray: 17 ³ / ₄ x 13 ¹ / ₈ x 4 ³ / ₈	Tray: 20 x 12 ¹ / ₂ x 4 ³ / ₈
Case Dimensions	15 ⁷ / ₈ x 6 ⁵ / ₈ x 20	19 ³ / ₄ x 6 ⁵ / ₈ x 23	22 ¹ / ₈ x 6 ⁵ / ₈ x 24 ³ / ₈
Case Cube	1.22	1.74	2.07
Case Weight (lbs)	13	20	21
Cases Per Pallet	42	42	36

Soup - N - Serve™ - U.S. Patent #7,325,718 B2



lunch boxes & drink carriers



Printed with water, vegetable, or soy based inks.
 Items fold flat for transport and storage efficiency.
 Disposable, sturdy construction.



Drink Carriers
 Push in straps allow smaller sized cups to stay secure while transported.
 (29501 & 29505)

Unique Features

- **Drink Carriers** - Made from moisture-resistant board. **2 Cup** - Holds 12-30 oz cups, **4 Cup** and **4 Cup Tall** hold 12-20 oz cups.
- **Lunch Boxes** - Disposable containers fit individual size servings and are stackable.
- Custom printing available

Lunch Boxes & Drink Carriers

- Clamshells
- Hot Cup Sleeves
- 96 oz. To Go
- Bulk Beverages
- Handled Carriers
- Catering
- Cups
- Lids
- Innovation



Product Description	2- Cup Drink Carrier Kraft	4 - Cup Drink Carrier Kraft	4 - Cup Tall Drink Carrier Kraft
Item Number	29501	29500	29505
Case Pack	250	200	200
Product Dimensions	8 x 3 ⁵ / ₈ x 10 ¹ / ₈	6 ⁷ / ₁₆ x 6 ⁷ / ₁₆ x 8 ³ / ₈	6 ¹⁵ / ₁₆ x 6 ¹⁵ / ₁₆ x 9 ³ / ₁₆
Case Dimensions	23 ³ / ₈ x 10 ¹ / ₂ x 12 ³ / ₈	21 ³ / ₈ x 9 x 13 ⁵ / ₈	20 ³ / ₈ x 10 x 14 ⁷ / ₈
Case Cube	1.76	1.52	1.75
Case Weight (lbs)	24	20	29
Cases Per Pallet	48	50	50

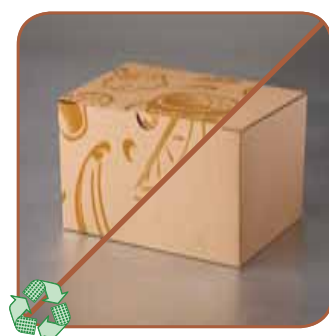

Product Description	Lunch Box Art Deco Print	Lunch Box Corrugated - Kraft	Lunch Box Paperboard - Kraft	Lunch Box Paperboard - White
Item Number	9608	9607	9620	9602
Case Pack	50	50	100	100
Product Dimensions	8 x 6 x 4	8 x 6 x 4	8 x 6 x 4	9 ¹ / ₂ x 7 ¹ / ₂ x 3 ⁵ / ₈
Case Dimensions	17 ³ / ₄ x 16 ³ / ₄ x 11 ⁷ / ₈	12 ³ / ₈ x 12 ³ / ₈ x 15	17 ⁵ / ₈ x 12 ⁵ / ₈ x 9 ¹ / ₄	
Case Cube	2.04	1.31	1.19	
Case Weight (lbs)	14	21	21	
Cases Per Pallet	36	36	56	



cups



Highest post - consumer fiber content in the industry.
Printed with water based inks.

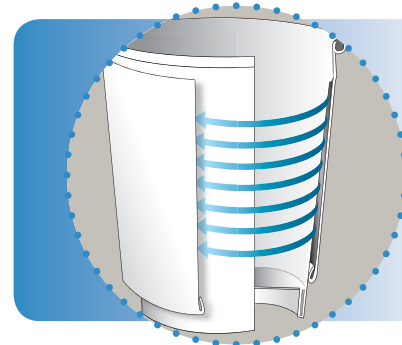

Calyx™ Cup Innovation

Patented double - wall design.
360° Air Chamber.
Ergonomic feel in hand.
Improved wall stability.

Unique Features

- Calyx™ cup offers a unique design that flairs out at the bottom to ensure consistent de-nesting for operational ease.
- Double wall paper cup
- Insulation ideally suited for coffee and other hot drinks
- Poly coated inner
- Custom printing available

Cups

- Clamshells
- Hot Cup Sleeves
- 96 oz. To Go
- Bulk Beverages
- Handled Carriers
- Catering
- Boxes & Carriers

Lids
Innovation



Product Description	Sumatra™ 4 Color Process Stock Print			Monaco™ 4 Color Process Stock Print		
	Item Number	3007	3008	3009	3010	3011
Case Pack	600	540	600	600	540	600
Product Dimensions	12 oz.	16 oz.	20 oz.	12 oz.	16 oz.	20 oz.
Case Dimensions	19 ³ / ₄ x 13 ¹ / ₈ x 24 ³ / ₈	19 ³ / ₄ x 13 ¹ / ₈ x 24 ³ / ₈	19 ³ / ₄ x 13 ¹ / ₈ x 24 ³ / ₈	19 ³ / ₄ x 13 ¹ / ₈ x 24 ³ / ₈	19 ³ / ₄ x 13 ¹ / ₈ x 24 ³ / ₈	19 ³ / ₄ x 13 ¹ / ₈ x 24 ³ / ₈
Case Cube	3.7	3.7	3.7	3.7	3.7	3.7
Case Weight (lbs)	26	24	26	26	24	26
Cases Per Pallet	28	28	28	28	28	28



Product Description	Sierra™ 2 Color Stock Print			Gourmet White Plain White Cup		
	Item Number	3004	3005	3006	3001	3002
Case Pack	600	540	600	600	540	600
Product Dimensions	12 oz.	16 oz.	20 oz.	12 oz.	16 oz.	20 oz.
Case Dimensions	19 ³ / ₄ x 13 ¹ / ₈ x 24 ³ / ₈	19 ³ / ₄ x 13 ¹ / ₈ x 24 ³ / ₈	19 ³ / ₄ x 13 ¹ / ₈ x 24 ³ / ₈	19 ³ / ₄ x 13 ¹ / ₈ x 24 ³ / ₈	19 ³ / ₄ x 13 ¹ / ₈ x 24 ³ / ₈	19 ³ / ₄ x 13 ¹ / ₈ x 24 ³ / ₈
Case Cube	3.7	3.7	3.7	3.7	3.7	3.7
Case Weight (lbs)	26	24	26	26	24	26
Cases Per Pallet	28	28	28	28	28	28

Calyx™ Cup US Pat. No. 6109518, German Pat. No. 19840841.2.
Additional US and Foreign Patent Applications Pending.



lids



Recyclable under recycle symbol number 6 polystyrene.

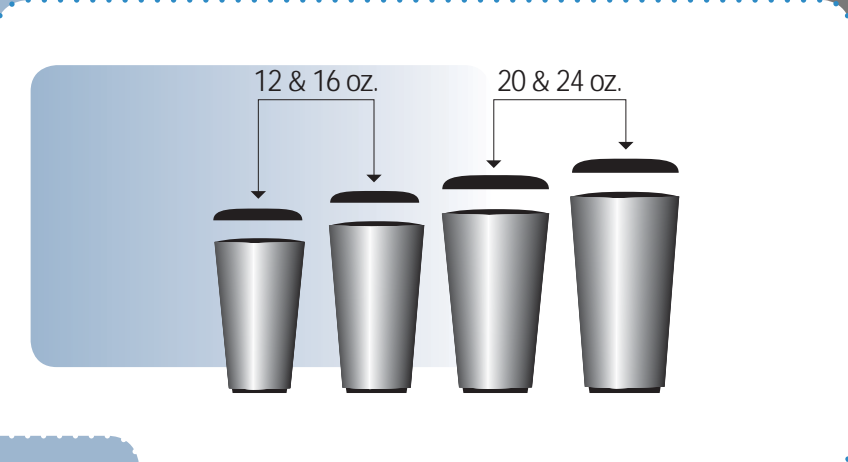

Unique Features

- Sip - Thru raised lid leaves room for whipped topping.
- Flat - Tear Back locks securely in place.
- Pull - N - Sip locks into place while leaving room for drink toppings.
- Perfect complement to our Calyx™ cup product line.
- Common lid sized for 12 & 16 and 20 & 24 oz.
- All styles available in black or white.

Lids

- Clamshells
- Hot Cup Sleeves
- 96 oz. To Go
- Bulk Beverages
- Handled Carriers
- Catering
- Boxes & Carriers
- Cups

Innovation

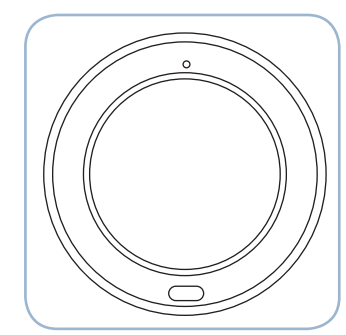
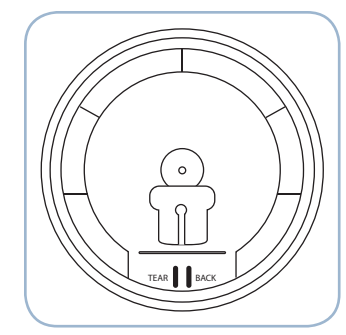

Product Description	Flat - Tear Back				Sip - Thru			
	Black 12&16 oz	White 12&16 oz	Black 20&24 oz	White 20&24 oz	Black 12&16 oz	White 12&16 oz	Black 20&24 oz	White 20&24 oz
Item Number	3013	3014	3019	3020	3015	3016	3021	3022
Case Pack	1000		1000		1000		1000	
Case Dimensions	19 x 7 ³ / ₄ x 18 ¹ / ₄		20 ⁵ / ₈ x 8 ¹ / ₂ x 17 ³ / ₄		19 x 7 ³ / ₄ x 19 ¹ / ₂		20 ⁵ / ₈ x 8 ¹ / ₂ x 18 ¹ / ₂	
Case Cube	1.6		1.8		1.7		1.9	
Case Weight (lbs)	8	7	8.47	7.7	8	7	8.47	7.7

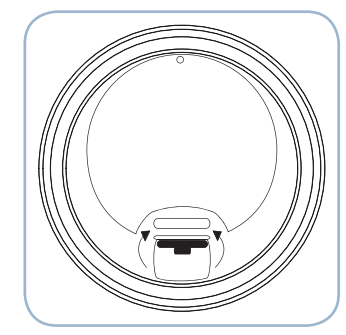

Product Description	Pull - N - Sip			
	Black 12&16 oz	White 12&16 oz	Black 20&24 oz	White 20&24 oz
Item Number	3017	3018	3023	3024
Case Pack	1000		1000	
Case Dimensions	19 x 7 ³ / ₄ x 18 ¹ / ₄		20 ⁵ / ₈ x 8 ¹ / ₂ x 18 ¹ / ₅	
Case Cube	1.6		1.9	
Case Weight (lbs)	8	7	8.47	7.7

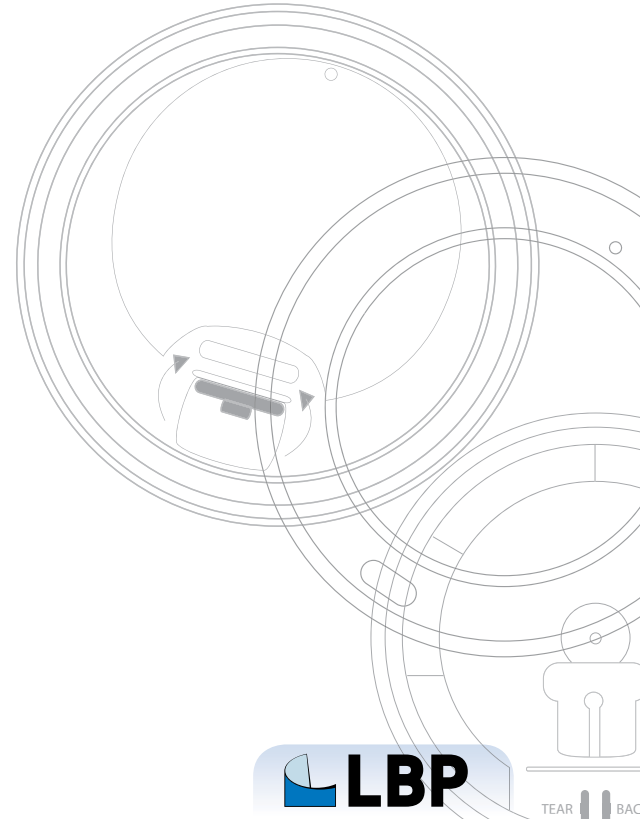

innovation & customization

LBP separates itself from the competition by offering customized packaging solutions including custom printing, new sizes, or development of a unique package.

LBP's team of experienced professionals, trained in the latest software, will work with you and your idea - **Concept to completion.**

printing

All products have been designed to easily be manufacturable in a variety of quantity ranges, allowing customers a branding opportunity. Printing can range from simple line or spot colors to 4 color process hi-resolution images and coatings. All options are reviewed by our Creative Services team to ensure the final product meets the look, price, and vision of your packaging idea.



solutions



The LBP Product Innovation Team supports the need for product innovation and design of our customers. Services include generating creative and feasible product designs, sampling/mock-ups, testing adhesives, coatings, inks, substrates, product performance evaluations, and managing new product development.

concept to completion



An Idea is born



Graphics Applied



Printing Proof



LBP Approval



Customer Approval

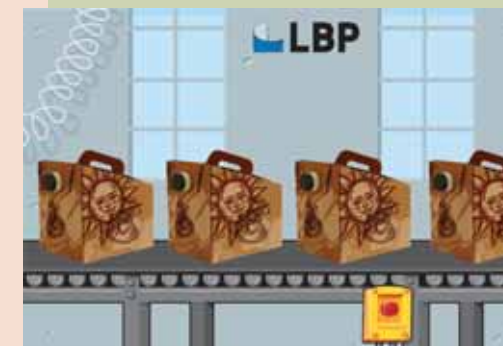

Production Manufacturing

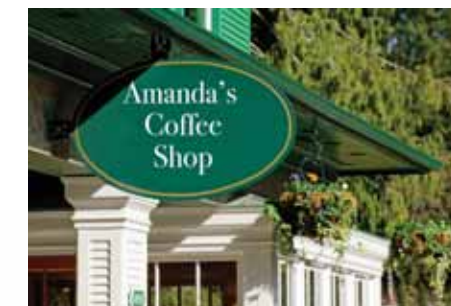

End User



Distribution

- Innovation
- Clamshells
 - Hot Cup Sleeves
 - 96 oz. To Go
 - Bulk Beverages
 - Handled Carriers
 - Catering
 - Boxes & Carriers
- Innovation